

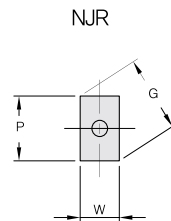

# PUNCH - NJ\_ PRESS FIT CENTER DOWEL EJECTOR PUNCH

## TYPE NJ\_

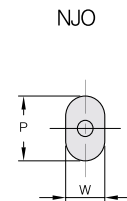
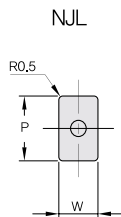
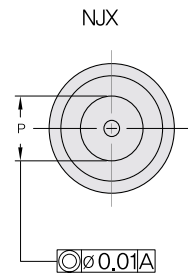
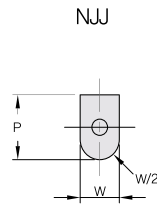
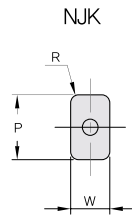
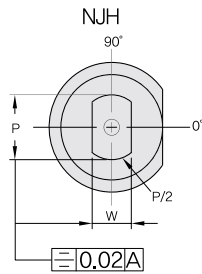
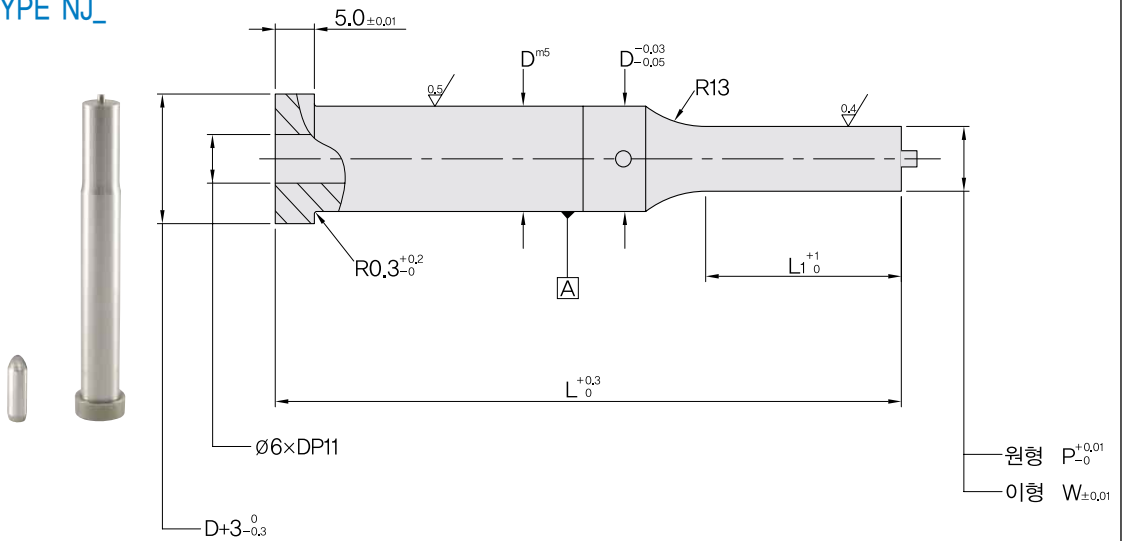

- \*  $P \geq W$
- \* R = 지정가능
- \*  $G = \sqrt{P^2 + W^2}$



# PUNCH - NJ\_ PRESS FIT CENTER DOWEL EJECTOR PUNCH

| 호칭경<br>D | L1   |      | Type&D | 원형          | Type&D | 이형<br>min. - max.<br>W P/G | L  |    |    |     |
|----------|------|------|--------|-------------|--------|----------------------------|----|----|----|-----|
|          | Std. | Alt. | NJX    | P           | NJ_    |                            | 71 | 80 | 90 | 100 |
| 10       | 19   | 25   | NJX10  | 4.50-9.99   | NJ_10  | 4.50-10.00                 | ●  | ●  | ●  | ●   |
| 13       | 19   | 25   | NJX13  | 6.00-12.99  | NJ_13  | 6.00-13.00                 | ●  | ●  | ●  | ●   |
| 16       | 19   | 25   | NJX16  | 8.00-15.99  | NJ_16  | 7.20-16.00                 | ●  | ●  | ●  | ●   |
| 20       | 19   | 25   | NJX20  | 10.00-19.99 | NJ_20  | 8.00-20.00                 | ●  | ●  | ●  | ●   |
| 25       | 19   | 25   | NJX25  | 12.00-24.99 | NJ_25  | 9.00-25.00                 | ●  | ●  | ●  | ●   |
| 32       | 25   | 30   | NJX32  | 16.00-31.99 | NJ_32  | 10.00-32.00                | ●  | ●  | ●  | ●   |

Threaded dowel 6mm×25

|            |             |    |   |    |   |    |   |            |
|------------|-------------|----|---|----|---|----|---|------------|
| 규격표기<br>방법 | Catalog No. | D  | - | L1 | - | L  | - | P,W        |
|            | NJX         | 16 | - | 19 | - | 80 | - | P8.0       |
|            | NJR         | 16 | - | 25 | - | 80 | - | P8.5, W8.0 |



# PUNCH - NP\_ PRESS FIT CENTER DOWEL PUNCH

## TYPE NP\_

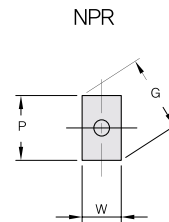
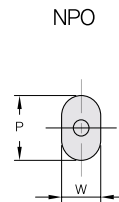
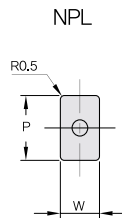
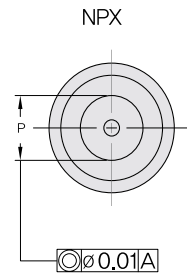
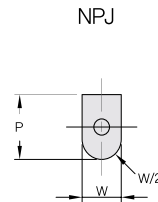
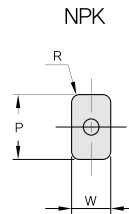
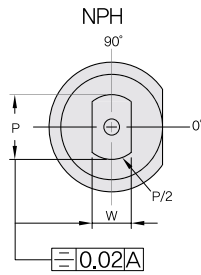
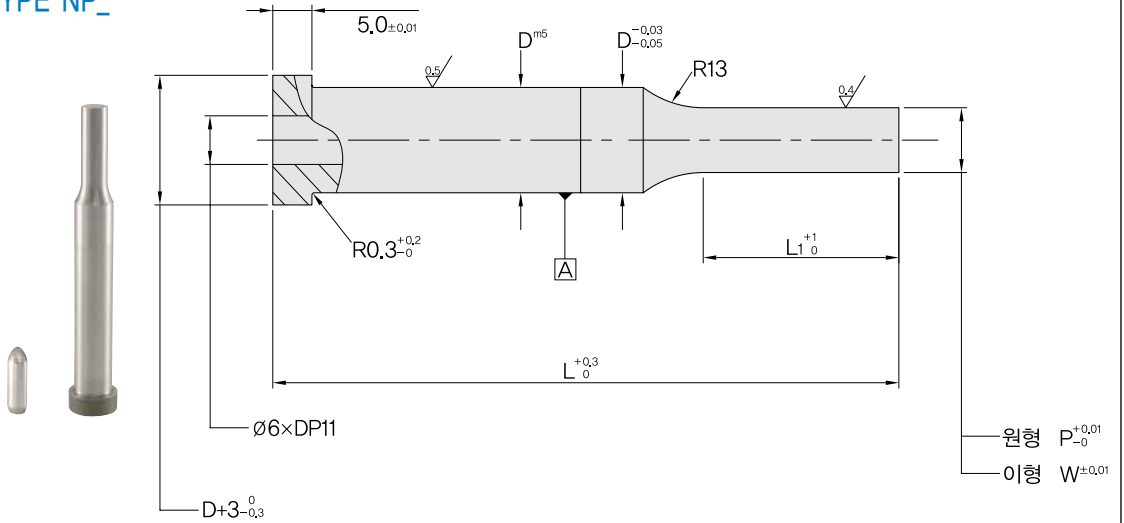

- \*  $P \geq W$
- \* R = 지정기능
- \*  $G = \sqrt{P^2 + W^2}$



# PUNCH – NP\_ PRESS FIT CENTER D OWEL PUNCH

| 호칭경<br>D | L1   |      | Type&D | 원형          | Type&D | 이형<br>min. - max.<br>W P/G | L  |    |    |     |
|----------|------|------|--------|-------------|--------|----------------------------|----|----|----|-----|
|          | Std. | Alt. | NPX    | P           | NP_    |                            | 71 | 80 | 90 | 100 |
| 10       | 19   | 25   | NPX10  | 4.50-9.99   | NP_10  | 4.50-10.00                 | ●  | ●  | ●  | ●   |
| 13       | 19   | 25   | NPX13  | 6.00-12.99  | NP_13  | 6.00-13.00                 | ●  | ●  | ●  | ●   |
| 16       | 19   | 25   | NPX16  | 8.00-15.99  | NP_16  | 7.20-16.00                 | ●  | ●  | ●  | ●   |
| 20       | 19   | 25   | NPX20  | 10.00-19.99 | NP_20  | 8.00-20.00                 | ●  | ●  | ●  | ●   |
| 25       | 19   | 25   | NPX25  | 12.00-24.99 | NP_25  | 9.00-25.00                 | ●  | ●  | ●  | ●   |
| 32       | 25   | 30   | NPX32  | 16.00-31.99 | NP_32  | 10.00-32.00                | ●  | ●  | ●  | ●   |

Threaded dowel 6mm ×25

|            |             |    |   |    |   |    |   |            |
|------------|-------------|----|---|----|---|----|---|------------|
| 규격표기<br>방법 | Catalog No. | D  | - | L1 | - | L  | - | P,W        |
|            | NPX         | 16 | - | 19 | - | 80 | - | P8.0       |
|            | NPR         | 16 | - | 25 | - | 80 | - | P8.5, W8.0 |